

Panasonic

Audio 4CH Camera Adapter

AJ-CA910P

Operating Instructions

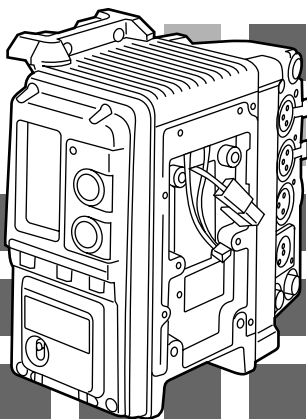



CAUTION

RISK OF ELECTRIC SHOCK
DO NOT OPEN



CAUTION: TO REDUCE THE RISK OF ELECTRIC SHOCK,
DO NOT REMOVE COVER (OR BACK).
NO USER SERVICEABLE PARTS INSIDE.
REFER TO SERVICING TO QUALIFIED SERVICE PERSONNEL.



The lightning flash with arrowhead symbol, within an equilateral triangle, is intended to alert the user to the presence of uninsulated “dangerous voltage” within the product’s enclosure that may be of sufficient magnitude to constitute a risk of electric shock to persons.



The exclamation point within an equilateral triangle is intended to alert the user to the presence of important operating and maintenance (service) instructions in the literature accompanying the appliance.

WARNING:

TO REDUCE THE RISK OF FIRE OR SHOCK HAZARD, DO NOT EXPOSE THIS EQUIPMENT TO RAIN OR MOISTURE.

CAUTION:

TO REDUCE THE RISK OF FIRE OR SHOCK HAZARD AND ANNOYING INTERFERENCE, USE THE RECOMMENDED ACCESSORIES ONLY.

CAUTION:

TO REDUCE THE RISK OF FIRE OR SHOCK HAZARD, REFER MOUNTING OF THE OPTIONAL INTERFACE BOARD TO QUALIFIED SERVICE PERSONNEL.

CAUTION:

TO REDUCE THE RISK OF FIRE OR SHOCK HAZARD, REFER CHANGE OF SWITCH SETTING INSIDE THE UNIT TO QUALIFIED SERVICE PERSONNEL.

 indicates safety information.

FCC Note:

This device complies with Part 15 of the FCC Rules. To assure continued compliance follow the attached installation instructions and do not make any unauthorized modifications.

This equipment has been tested and found to comply with the limits for a class A digital device, pursuant to Part 15 of the FCC Rules. These limits are designed to provide reasonable protection against harmful interference when the equipment is operated in a commercial environment. This equipment generates, uses, and can radiate radio frequency energy and, if not installed and used in accordance with the instruction manual, may cause harmful interference to radio communications. Operation of this equipment in a residential area is likely to cause harmful interference in which case the user will be required to correct the interference at his own expense.

**ATTENTION:**

The product you have purchased is powered by a nickel cadmium battery which is recyclable. At the end of its useful life, under various state and local laws, it is illegal to dispose of this battery into your municipal waste stream.

Please call 1-800-8-BATTERY for information on how to recycle this battery.

 indicates safety information.

Contents

| | |
|---------------------------------|---|
| Models Supported | 4 |
| Specifications | 4 |
| Parts and Their Functions | 5 |
| Attachment to Camera | 7 |

Models Supported

Camera recorders

- AJ-D910WA,
AJ-D900W, AJ-D900WA
AJ-PD900W, AJ-PD900WA

Specifications

| |
|--|
| Power supply: DC 12 V (11 V–17 V) |
| Power consumption: 7 W (including the optional board) |

Ambient operating temperature:

0°C to +40°C

Storage temperature:

–20°C to +60°C

Ambient operating humidity:

Less than 85% (relative humidity)

Audio sampling frequency:

48 kHz (synchronized with video)

Audio quantizing:

16 bits

Parts and Their Functions

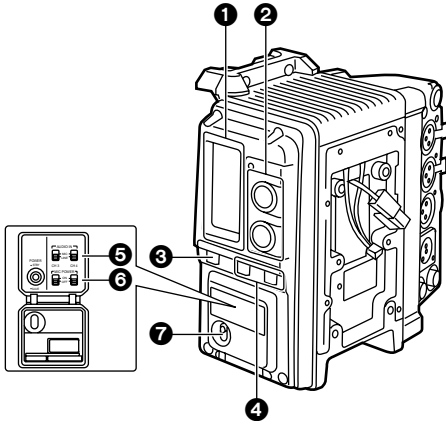

1 Audio CH 3/CH 4 level meter

2 AUDIO LEVEL CH 3/CH 4 (audio channel 3/4 recording level) controls

When the AUDIO SELECT CH 3/CH 4 switch 4 is set to MAN, the recording levels of the audio channel 3 and 4 signals can be adjusted using these controls.

3 MONITOR SELECT (audio channel selector) switch

This is used to select the audio channel whose signals are to be output from the AUDIO OUT connector or PHONES jack.

CH 3 : The audio CH 3 signals are output.

CH 4 : The audio CH 4 signals are output.

ST/MIX: The audio CH 3 and CH 4 signals are mixed and output to the AUDIO OUT connector. Stereo audio signals are output to the PHONES jack.

4 AUDIO SELECT CH 3/CH 4 (audio channel 3/4 automatic/manual level adjustment selector) switch

This is used to select the method for adjusting the audio channel 3 and/or 4 recording level.

AUTO : The recording level is adjusted automatically.

MAN : The recording level is adjusted manually.

5 AUDIO IN CH 3/CH 4 (audio input selector) switches

These are used to select the input signals which are to be recorded on audio channels 3 and 4.

MIC : The audio signals from the mic input are recorded.

LINE : The audio signals which are input from the audio component are recorded.

6 MIC POWER CH 3/CH 4 (mic power selector) switches

These are used to turn on or off the power to the microphones which are connected to the AUDIO IN CH 3 and CH 4 connectors.

ON : Power (+48 V) for phantom microphones is supplied.

OFF : No power is supplied.

7 POWER switch

This controls the camera adapter's power.

STBY : The unit's power is turned on or off in tandem with the setting of the power switch on the camera.

SAVE : The camera adapter's power is turned off regardless of the setting of the power switch on the camera.

Parts and Their Functions

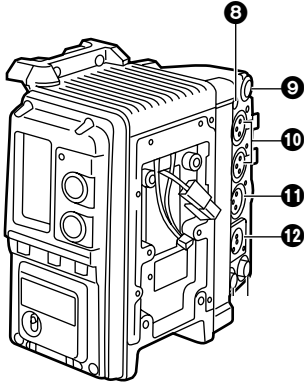

8 PHONES (headphones) jack

Stereo mini jack

9 PHONES LEVEL (headphones output level adjustment) control

This is used to adjust the level of the audio output from the PHONES jack.

10 AUDIO IN CH 3/CH 4 (audio input channel 3/4) connectors (XLR, 3-pin)

The audio component or microphones are connected to these connectors.

XLR, 3-pin, female
LINE/MIC switching type
LINE : +4 dBu (can be changed to 0 dBu using internal switch)
MIC : -60 dBu (can be changed to -40 dBu using internal switch)
Phantom power supplies supported.

11 AUDIO OUT connector

This is connected to the audio component.

The audio output channel is selected using the MONITOR SELECT switch 6.

XLR, 3-pin, male
+4 dBu (can be changed using internal control)

12 DC IN (external power input) socket (XLR, 4P)

Connect the AJ-B75 (optional accessory) AC adapter to this socket when AC power is to be used to operate the camera adapter.

XLR, 4-pin, male
DC 12 V (DC 11 V-17 V)

Operating Cautions

- Set the EMPHASIS item of the audio menu of the camera unit to OFF before use.
- Please consult your local dealer or service center when changing the settings of the switches or VR inside the unit.

Attachment to Camera

- Consult with your dealer or a Panasonic Service Center representative before attaching this camera adapter.
- Take care not to make direct contact with the connector pins.

1 Remove the battery mount from the camera.

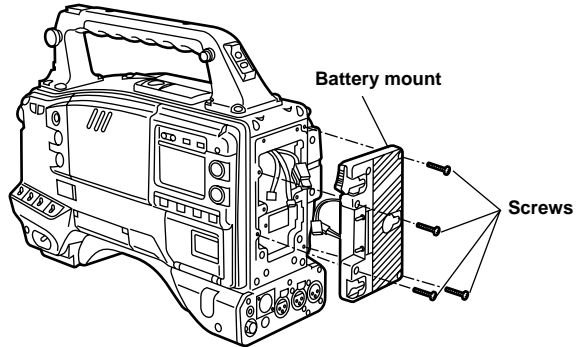

2 Connect the connectors on the camera adapter to the connectors on the camera unit.

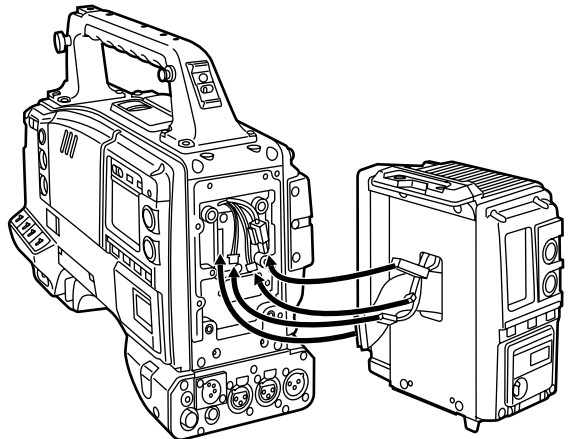

<Notes>

- Take care to avoid damaging the flexible board during the attachment procedure.
- Take care to avoid pinching the connector cords during the attachment procedure.

Attachment to Camera

- 3 Use the 4 screws packed with the camera adapter to screw the camera adapter onto the camera.

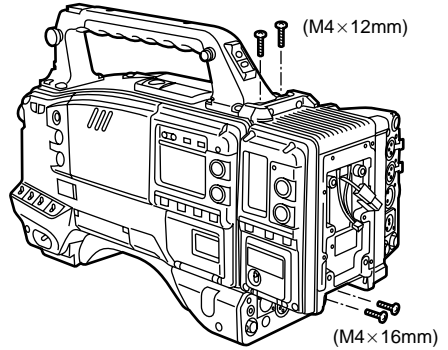

- 4 Connect the connectors on the battery mount to the connectors on the camera adapter.

<Note>

Take care to avoid pinching the connector cords during the attachment procedure.

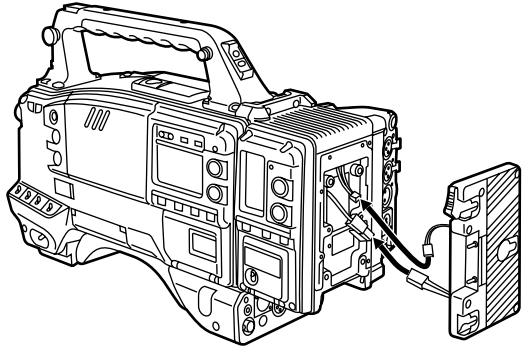

- 5 Use the screws to screw the battery mount onto the camera adapter.

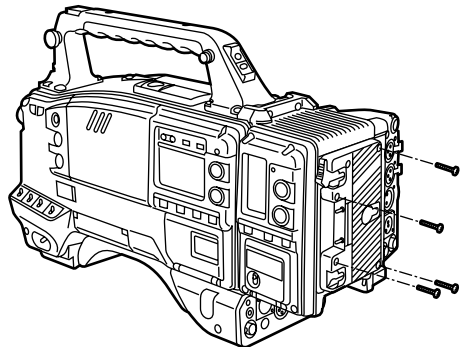

Panasonic

PANASONIC BROADCAST & TELEVISION SYSTEMS COMPANY
DIVISION OF MATSUSHITA ELECTRIC CORPORATION OF AMERICA

Executive Office:

3330 Cahuenga Blvd W., Los Angeles, CA 90068 (323) 436-3500

EASTERN ZONE:

One Panasonic Way 4E-7, Secaucus, NJ 07094 (201) 348-7621

Southeast Region:

1225 Northbrook Parkway, Ste 1-160, Suwanee, GA 30024 (770) 338-6835

Central Region:

1707 N Randall Road E1-C-1, Elgin, IL 60123 (847) 468-5200

WESTERN ZONE:

3330 Cahuenga Blvd W., Los Angeles, CA 90068 (323) 436-3500

Government Marketing Department:

52 West Gude Drive, Rockville, MD 20850 (301) 738-3840

Broadcast PARTS INFORMATION & ORDERING:

9:00 a.m. – 5:00 p.m. (EST) (800) 334-4881/24 Hr. Fax (800) 334-4880

Emergency after hour parts orders (800) 334-4881

TECHNICAL SUPPORT:

Emergency 24 Hour Service (800) 222-0741

Panasonic Canada Inc.

5770 Ambler Drive, Mississauga, Ontario L4W 2T3 (905) 624-5010

Panasonic de Mexico S.A. de C.V.

Av angel Urraza Num. 1209 Col. de Valle 03100 Mexico, D.F. (52) 1 951 2127

Panasonic Sales Company

Division of Matsushita Electric of Puerto Rico Inc.

San Gabriel Industrial Park, 65th Infantry Ave., Km. 9.5, Carolina, Puerto Rico 00630 (787) 750-4300